

316GR SKID STEER SPECIFICATIONS

Engine		316GR	
Manufacturer and Model	Yanmar 4TNV86CHT	Displacement	2.1 L (128 cu. in.)
Non-Road Emission Standard	EPA Final Tier 4/EU Stage IV	Rated Engine Speed	2,600 rpm
Cylinders	4	Torque Rise	21% at 1,690 rpm
Net Power (SAE J1349 / ISO 9249)	45.6 kW (61 hp) at 2,600 rpm	Aspiration	Turbocharged
Gross Rated Power (ISO 14396)	48.5 kW (65 hp) at 2,600 rpm	Air Cleaner	Dry dual element
Peak Torque	207 Nm (153 ft.-lb.) at 1,690 rpm		
Cooling			
Fan Type	Direct belt drive		
Powertrain			
Type	Hydrostatic-manual or electrohydraulic (EH); 4 – 80 heavy-duty (HD) continuous-loop chain		
Speeds			
Single	11.1 km/h (6.9 mph)		
2 Speed, High	16.3 km/h (10.1 mph)		
Axles		Induction-hardened, 1-piece forged axle shafts with maintenance-free oil-bath lubrication of inner and outer axle bearings	
Maximum Axle Torque	6459 Nm (4,764 lb.-ft.)		
Tractive Effort	3552 kgf (7,831 lbf)		
Final Drive		High-strength, adjustment-free chains	
Brakes		Integral, automatic, spring-applied, hydraulically released, wet-disc park brake	
Hydraulics			
Pump Flow, Standard	63 L/m (17 gpm)		
System Pressure at Couplers	23 787 kPa (3,450 psi)		
Hydraulic Horsepower Flow (calculated), Standard	25 kW (33 hp)		
Auxiliary Hydraulics	Optional connect-under-pressure with flat-faced couplers		
Cylinders			
Type	John Deere heat-treated, chrome-plated polished cylinder rods, hardened steel (replaceable bushings) pivot pins		
Electrical			
Voltage	12 volt		
Battery Capacity	750 CCA standard / 925 CCA with optional cold weather start package		
Alternator Rating	70 amp with no air conditioning (A/C) / 90 amp with A/C		
Lights			
Standard	Halogen: 2 front and 1 rear		
Deluxe	LED: 2 front, 2 side, and 1 rear		
Operator's Station			
	ROPS (ISO 3471) / FOPS (ISO 3449) structure with quick pivot standard		
Tires/Wheels			
Standard Tire Size	10 x 16.5		
Serviceability			
Refill Capacity			
Fuel Tank	71 L (19 gal.)		
Operating Weight			
Base Machine	2806 kg (6,180 lb.)		
Machine Dimensions			
A Length Without Bucket	2.63 m (103.0 in.) (8 ft. 7 in.)		
B Length With Foundry Bucket	3.24 m (127.6 in.) (10 ft. 8 in.)		
C Width Without Bucket	1.60 m (62.9 in.) (5 ft. 3 in.)		
D Height to Top of ROPS	1.96 m (77.2 in.) (6 ft. 5 in.)		
E Height to Hinge Pin	2.92 m (115.1 in.) (9 ft. 7 in.)		
F Dump Height With Foundry Bucket	2.25 m (88.6 in.) (7 ft. 5 in.)		
G Dump Reach			
With Foundry Bucket	0.40 m (15.8 in.)		
With Construction Bucket	0.58 m (22.8 in.)		
H Wheelbase	1.05 m (41.5 in.) (3 ft. 5 in.)		
I Ground Clearance	0.18 m (7.0 in.)		
J Angle of Departure	22.3 deg.		
K Front Turn Radius With Foundry Bucket	2.01 m (79.0 in.) (6 ft. 7 in.)		
L Dump Angle (full lift height)	45 deg.		
M Bucket Rollback (ground level)	30 deg.		

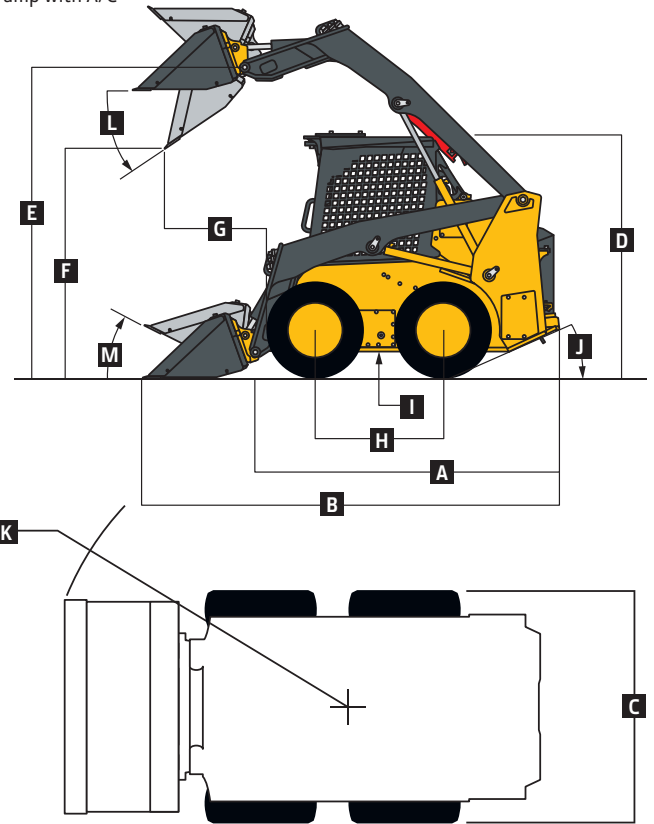

While general information, pictures, and descriptions are provided, some illustrations and text may include product options and accessories NOT AVAILABLE in all regions, and in some countries products and accessories may require modifications or additions to ensure compliance with the local regulations of those countries.

Loader Performance		316GR	
Tipping Load	1589 kg (3,500 lb.)	Boom Breakout Force <i>(continued)</i>	
SAE Rated Operating Capacity	795 kg (1,750 lb.)	With Construction Bucket	2043 kg (4,500 lb.)
With Counterweight	863 kg (1,900 lb.)	Bucket Breakout Force	
Boom Breakout Force		With Foundry Bucket	2384 kg (5,250 lb.)
With Foundry Bucket	2157 kg (4,750 lb.)	With Construction Bucket	1816 kg (4,000 lb.)

Additional equipment

Key: ● Standard ▲ Optional or special

See your John Deere dealer for further information.

316GR Engine

- Meets EPA Final Tier 4/EU Stage IV emissions
- Yanmar 4TNV86CMT
- Auto-idle
- Automatic preheat
- Electronic injection system
- ▲ Engine air precleaner kit
- Fuel tank, 71 L (19 gal.)
- John Deere COOL-GARD™ II Extended-Life Engine Coolant
- John Deere Plus-50™ II 0W40 initial engine oil fill*

- 4-cylinder 48.5 kW (65 gross hp)/ 45.6 kW (61 net hp), 2.1-L (128 cu. in.) displacement
- 5-micron primary fuel filter and water separator
- ▲ Cold-weather starting package with 925-CCA battery

Cooling System

- Coolant overflow bottle recovery tank
- Direct belt-drive cooling fan system
- No-tools-required swing-out oil cooler

Powertrain

- High-strength adjustment-free final-drive chains
- Automatic spring-applied hydraulically released wet-disc park brake
- Transmission, single speed
- ▲ Transmission, 2 speed

Hydraulic System

- John Deere heat-treated, chrome-plated cylinder rods with replaceable bushings
- ▲ Connect-under-pressure auxiliary couplers
- Quick-check hydraulic fluid-level sight glass
- 1,000-hour, 5-micron hydraulic filter
- Axial-piston hydrostatic pump

Electrical

- Automatic engine/hydraulic shutdown protection system
- Auxiliary hydraulics operator-presence system
- Courtesy lighting

316GR Electrical *(continued)*

- Deluxe instrumentation EMU with: Operator-selectable monitoring – Hour meter, engine rpm, battery voltage, diagnostics, EMU configuration, engine coolant temperature, hydraulic oil temperature / LED warning indicators – Glow plug, seat switch, seat belt, door open, auxiliary hydraulics, park brake engaged, 2-speed engaged, stop, low engine oil pressure, engine coolant over-temperature, battery not charging, air filter restriction, hydraulic filter restriction

- ▲ Deluxe LED lighting package with additional side lights (2), front lights (2), and rear light (1)
- Front and rear halogen work lights

- Triple-interlock operator-presence control system

- Backup alarm
- Battery, 750 CCA
- Horn

Operator's Station

- Deluxe cab headliner
- ▲ Keyless-start sealed-switch module with integrated anti-theft system
- Pull-down adjustable lap bar
- Quick-pivot ROPS
- Rear window
- Top window
- Removable top window
- ▲ Vinyl cab enclosure
- ▲ Glass cab enclosure
- ▲ Sliding/locking/removable glass side windows
- ROPS/FOPS operator structure
- Seat belt, 51-mm (2-in.), retractable
- ▲ Seat belt, 76-mm (3-in.), retractable
- ▲ Shoulder belt
- Water-shedding deluxe vinyl seat
- ▲ Air-ride cloth, heated seat
- ▲ Air-ride vinyl seat

316GR Operator's Station *(continued)*

- 12-volt power port / Dome light / Cargo storage / Beverage holder
- ▲ Air conditioning with heater/defroster
- ▲ AM/FM radio with Bluetooth® for audio streaming
- Electrohydraulic (EH) ISO-pattern joystick controls

- ▲ EH joystick performance package: Switchable ISO-H pattern / Creeper mode / Boom/bucket speed settings / Adjustable propel settings / Attachment controls

- ▲ Floor mat with left footrest

- Rearview mirror
- ▲ Boom-mounted side mirrors
- ▲ Rearview camera

Loader

- In-cab boom lockout to secure loader before exiting seat
- John Deere Quik-Tatch™
- ▲ Power Quik-Tatch
- John Deere radial-lift boom
- ▲ Hydraulic self-leveling on/off
- ▲ Ride control

Other

- Convenient front (1) and rear (2) tie-downs
- Environmental drains for all fluid reservoirs
- ▲ 10 x 16.5 10 PR Galaxy "Beefy Baby III" heavy-duty (HD) tires for 1.52-m (60 in.) machine width
- ▲ Tire options: SKS Xtra Wall, Galaxy Beefy Baby III, Galaxy Hulk, and Brawler Solid-Flex Chrome exhaust stack
- ▲ Rear counterweights (2), 45.36 kg (100 lb.)
- ▲ Single-point lift kit
- ▲ SMV sign kit
- ▲ JDLINK™ wireless communication system (available in specific countries; see your dealer for details)

*500-hour engine oil-change intervals when John Deere Plus-50 II oil and John Deere oil filter are used.

While general information, pictures, and descriptions are provided, some illustrations and text may include product options and accessories NOT AVAILABLE in all regions, and in some countries products and accessories may require modifications or additions to ensure compliance with the local regulations of those countries.

Net engine power is with standard equipment including air cleaner, exhaust system, alternator, and cooling fan, at standard conditions per SAE J1349 and DIN 6270B, using No. 2-D fuel at 35 API gravity. Gross power is without cooling fan. Specifications and design subject to change without notice. Wherever applicable, specifications are in accordance with SAE standards. Except where otherwise noted, these specifications are based on a unit with standard equipment, full fuel tank, and 79-kg (175-lb.) operator.