

# 331G COMPACT TRACK LOADER SPECIFICATIONS

<b>Engine</b>		<b>331G</b>	
Manufacturer and Model	Yanmar 4TNV94FHT	Displacement	3.1 L (186.3 cu. in.)
Non-Road Emission Standard	EPA Final Tier 4/EU Stage IV	Rated Engine Speed	2,500 rpm
Cylinders	4	Torque Rise	47% at 1,700 rpm
Gross Rated Power (ISO 14396)	68 kW (91.2 hp) at 2,500 rpm	Aspiration	Turbocharged, intercooled
Net Power (SAE J1349 / ISO 9249)	66 kW (88.5 hp) at 2,500 rpm	Air Cleaner	Dry dual element
Peak Torque	382 Nm (281.8 ft.-lb.) at 1,700 rpm		

<b>Cooling</b>	
Fan Type	Variable-speed hydraulic drive standard / reversing fan drive optional

<b>Powertrain</b>			
Pump	Axial-piston hydrostatic	Travel Speeds (continued)	
Controls	Electrohydraulic	2 Speed, High	12.6 km/h (7.8 mph)
Travel Speeds		<b>Brake</b>	Integral, automatic, spring-applied, hydraulically released wet-disc brake
2 Speed, Low	8.5 km/h (5.3 mph)		

<b>Undercarriage</b>			
<b>Rubber Tracks</b>	New-Generation smooth-ride long-life rubber with steel inserts	Track Rollers (per side)	5 triple-flange smooth-ride all-steel rollers
Track Width		Track Idlers (per side)	2 double-flange smooth-ride all-steel rollers
Standard	400 mm (15.8 in.)	Bearings/Seals (rollers/idlers)	Heavy-duty journal bearings and metal face seals
Optional	450 mm (17.7 in.)	Tractive Effort	5221 kgf (11,500 lbf)
Ground Pressure			
With Standard 400-mm (15.8 in.) Track	38.1 kPa (5.5 psi)		
With Optional 450-mm (17.7 in.) Track	33.9 kPa (4.9 psi)		

<b>Hydraulics</b>			
Pump Flow		Hydraulic Horsepower Flow (calculated)	
Standard	80 L/m (23.5 gpm)	Standard	35 kW (47 hp)
Total With High-Flow Option	138 L/m (36.5 gpm)	High	55 kW (73 hp)
System Pressure at Couplers	23 787 kPa (3,450 psi)		

<b>Cylinders</b>	
Type	John Deere heat-treated, chrome-plated polished cylinder rods, hardened steel (replaceable bushings) pivot pins

<b>Electrical</b>	
Voltage	12 volt
Battery Capacity	925 CCA
Alternator Rating	90 amp
<b>Lights</b>	Halogen: 2 front and 1 rear standard / deluxe LED: 4 front and 1 rear optional

<b>Operator's Station</b>	
ROPS (ISO 3471) / FOPS (ISO 3449) structure with quick-pivot standard	

<b>Serviceability</b>	
<b>Refill Capacity</b>	
Fuel Tank	114 L (30 gal.)

<b>Operating Weights</b>	
With Standard 400-mm (15.8 in.) Track	5403 kg (11,900 lb.)
With Optional 450-mm (17.7 in.) Track	5448 kg (12,000 lb.)

<b>Machine Dimensions</b>	
<b>A</b> Length Without Bucket	3.10 m (122 in.) (10 ft. 2 in.)
<b>B</b> Length With Foundry Bucket	3.71 m (146 in.) (12 ft. 2 in.)
<b>C</b> Width Without Bucket	
With 400-mm (15.8 in.) Track	2.00 m (78.9 in.) (6 ft. 7 in.)
With 450-mm (17.7 in.) Track	2.05 m (80.7 in.) (6 ft. 9 in.)
<b>D</b> Height to Top of ROPS	2.20 m (86.7 in.) (7 ft. 3 in.)
<b>E</b> Height to Hinge Pin	3.35 m (132 in.) (11 ft. 0 in.)
<b>F</b> Dump Height With Foundry Bucket	2.69 m (106.1 in.) (8 ft. 10 in.)
<b>G</b> Dump Reach	
With Foundry Bucket	0.71 m (28 in.)
With Construction Bucket	0.88 m (34.6 in.) with no edge
<b>H</b> Ground Clearance	0.24 m (9.4 in.)
<b>I</b> Angle of Departure	31 deg.
<b>J</b> Front Turn Radius With Foundry Bucket	2.18 m (85.7 in.) (7 ft. 2 in.)
<b>K</b> Dump Angle (full lift height)	48 deg.
<b>L</b> Bucket Rollback (ground level)	35 deg.

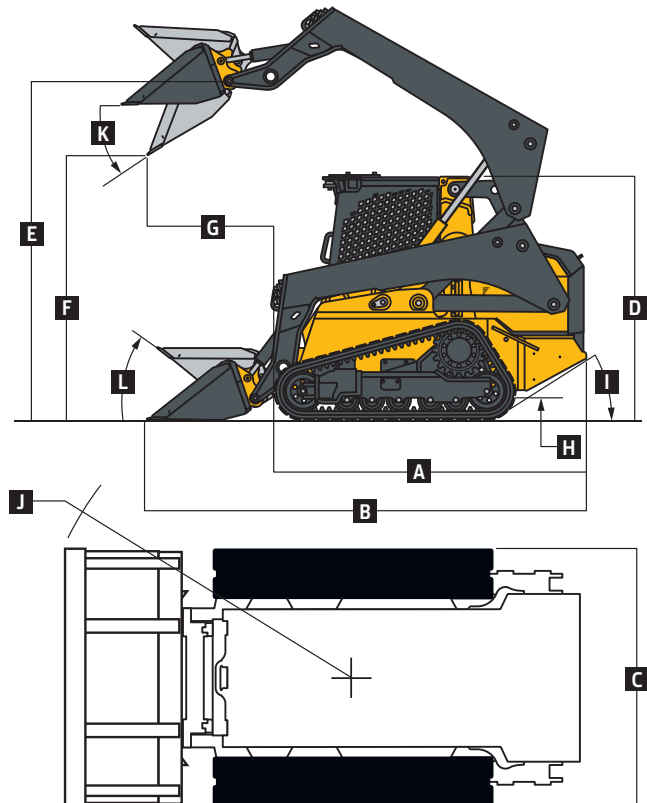

While general information, pictures, and descriptions are provided, some illustrations and text may include product options and accessories NOT AVAILABLE in all regions, and in some countries products and accessories may require modifications or additions to ensure compliance with the local regulations of those countries.

Loader Performance		331G	
Tipping Load	4021 kg (8,857 lb.) with construction bucket	Boom Breakout Force	
SAE Rated Operating Capacity		With Foundry Bucket	2724 kg (6,000 lb.)
At 35% Tipping Load	1407 kg (3,100 lb.) with construction bucket	With Construction Bucket	2724 kg (6,000 lb.)
At 50% Tipping Load	2011 kg (4,429 lb.) with construction bucket	Bucket Breakout Force	
		With Foundry Bucket	4688 kg (10,325 lb.)
		With Heavy-Duty Construction Bucket	3450 kg (7,600 lb.)

# Additional equipment

Key: ● Standard ▲ Optional or special

See your John Deere dealer for further information.

## 331G Engine

- Meets EPA Final Tier 4/EU Stage IV emissions
- Yanmar 4TNV94FHT
- Auto-idle
- Automatic fan tensioner
- Automatic preheat
- Electronic injection system
- ▲ Engine air precleaner kit
- Fuel tank, 114 L (30 gal.)
- John Deere COOL-GARD™ II Extended-Life Engine Coolant
- John Deere Plus-50™ 10w30 initial engine oil fill<sup>6</sup>
- 4-cylinder 68.0 kW (91.2 gross hp)/66.0 kW (88.5 net hp), 3.1-L (186.3 cu. in.) displacement
- 5-micron primary fuel filter and water separator
- ▲ Cold-weather starting package

## Cooling System

- Coolant surge tank
- Variable-speed hydraulically driven fan cooling system
- ▲ Reversing fan drive

## Powertrain

- High-torque heavy-duty planetary-reduction final drive
- Automatic spring-applied hydraulically released wet-disc park brake
- Wet-disc brakes
- Transmission, 2 speed

## Hydraulic System

- John Deere hydraulic cylinders with cushioned boom cylinders
- John Deere heat-treated, chrome-plated cylinder rods with replaceable bushings
- Connect-under-pressure auxiliary couplers
- Quick-check hydraulic fluid-level sight glass
- 1,000-hour, 5-micron hydraulic filter
- ▲ High-flow hydraulics
- Axial-piston hydrostatic pump

## Electrical

- Automatic engine/hydraulic shutdown protection system
- Auxiliary hydraulics operator-presence system
- Courtesy lighting
- Deluxe instrumentation EMU with: Operator-selectable monitoring – Hour meter, engine rpm, battery voltage, diagnostics, EMU configuration,

## 331G Electrical (continued)

engine coolant temperature, hydraulic oil temperature / LED warning indicators – Glow plug, seat switch, seat belt, door open, auxiliary hydraulics, park brake engaged, 2-speed engaged, stop, low engine oil pressure, engine coolant over-temperature, battery not charging, air filter restriction, and hydraulic filter restriction

- ▲ Deluxe LED lighting package with additional cab-integrated side lights (2)
- Front and rear halogen work lights
- Triple-interlock operator-presence control system
- Backup alarm
- Battery, 925 CCA
- Horn
- ▲ Hazard warning lights
- ▲ Strobe light, amber

## Operator's Station

- Deluxe cab headliner
- Electrohydraulic (EH) ISO-pattern joystick controls
- ▲ ISO-H switchable joystick controls and EH joystick performance package\*
- ▲ 4-way switchable controls include EH foot control, ISO joystick control, H-pattern joystick control, and ISO and foot controls
- ▲ ISO controls with programmable detents and EH boom performance package;† also includes EH joystick performance package\*
- ▲ Onboard grade indication: Grade-control option delivers onboard readout within LCD monitor that provides slope of blade (cross-slope direction) and mainfall (fore/aft direction) within ±0.5-percent accuracy
- Keyless-start sealed-switch module with integrated anti-theft system and operator memory preference settings
- Electronic push-button auxiliary controls
- Pull-down adjustable lap bar
- Quick-pivot ROPS
- Rear window
- Removable top window
- ▲ Sliding/locking/removable glass side windows
- ROPS/FOPS operator structure
- ▲ Glass cab enclosure
- Seat belt, 51 mm (2 in.), retractable
- ▲ Shoulder belt, 51 mm (2 in.) or 76 mm (3 in.)

## 331G Operator's Station (continued)

- ▲ Severe-duty cab door and wiper system
- Water-shedding deluxe vinyl suspension seat
- ▲ Air-ride cloth, heated seat
- ▲ Air-ride vinyl seat
- 12-volt power port / Dome light / Cargo storage / Beverage holder
- ▲ Air conditioning with heater/defroster
- ▲ AM/FM radio with auxiliary input and Bluetooth® for audio streaming
- ▲ Floor mat with left footrest
- Rearview mirror
- ▲ Rearview camera

## Loader

- In-cab boom lockout to secure loader before exiting seat
- Patented John Deere Quik-Tatch™ (no grease required)
- ▲ Power Quik-Tatch
- Patented John Deere vertical-lift boom
- ▲ Hydraulic self-leveling on/off and ride control

## Other

- Convenient front and rear tie-downs
- Environmental drains for all fluid reservoirs
- ▲ Chrome exhaust stack
- ▲ Engine oil/hydraulic fluid-sampling kit
- ▲ Forestry protection packages
- ▲ Heavy-duty rear grille
- ▲ Rear counterweights (available in sets of 1, 2, or 3), 78 kg (172 lb.) (each set)
- ▲ Single-point lift kit
- ▲ SMV sign kit
- Track, 400-mm (15.8 in.) wide
- ▲ Track, 450-mm (17.7 in.) wide
- ▲ JDLink™ wireless communication system (available in specific countries; see your dealer for details)

<sup>6</sup>500-hour engine oil-change intervals when John Deere Plus-50 oil and John Deere oil filter are used.

\*EH joystick performance package features switchable accelerator/decelerator, selectable propel speeds, creep control, boom- and bucket-speed settings, and 12-volt 3- and 14-pin attachment-control harness with dash-mounted 4th-function rocker switch.

†EH boom performance package features include EH bucket self-level up and down, return to dig, return to carry, and boom-height kick-out.

While general information, pictures, and descriptions are provided, some illustrations and text may include product options and accessories NOT AVAILABLE in all regions, and in some countries products and accessories may require modifications or additions to ensure compliance with the local regulations of those countries.

Net engine power is with standard equipment including air cleaner, exhaust system, alternator, and cooling fan, at standard conditions per SAE J1349 and DIN 6270B, using No. 2-D fuel at 35 API gravity. Gross power is without cooling fan. Specifications and design subject to change without notice.

Wherever applicable, specifications are in accordance with SAE standards. Except where otherwise noted, these specifications are based on a unit with standard equipment, full fuel tank, and 79-kg (175-lb.) operator.